

DIN EN13709

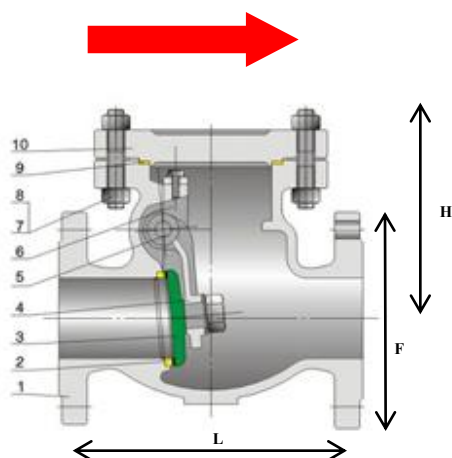



Item	Description	Material
1	Body	Cast iron
2	Seat	AISI304
3	Obturator	Cast iron with ring AISI304
5	Stem	X20Cr13
7	Screw	8.8
9	Nut	8.8
9	Packing	SBR (caoutchouc)
10	Cover	Cast iron

BASIC DESIGN STANDARDS	
Basic Design	DIN EN13709
Face to face	DIN EN 558-1
Flanged dimensions	EN1092 - 2
Testing	EN 12266-1

Maximum operating conditions	
-10 + 80°C	16 BAR
+80+120°C	16 BAR
+120-150°C	13 BAR

DN	PN16			
	L	F	H	Kg
1.½" (DN 40)	180	150	115	8
2" (DN 50)	200	165	125	10
2.½" (DN 65)	240	185	130	15
3" (DN 80)	260	200	140	20
4" (DN 100)	300	220	160	26
5" (DN125)	350	250	180	35
6" (DN 150)	400	285	200	48
8" (DN 200)	500	340	220	72
10" (DN 250)	600	405	290	135
12" (DN 300)	700	460	330	196