

**API 6D & Fire safe**

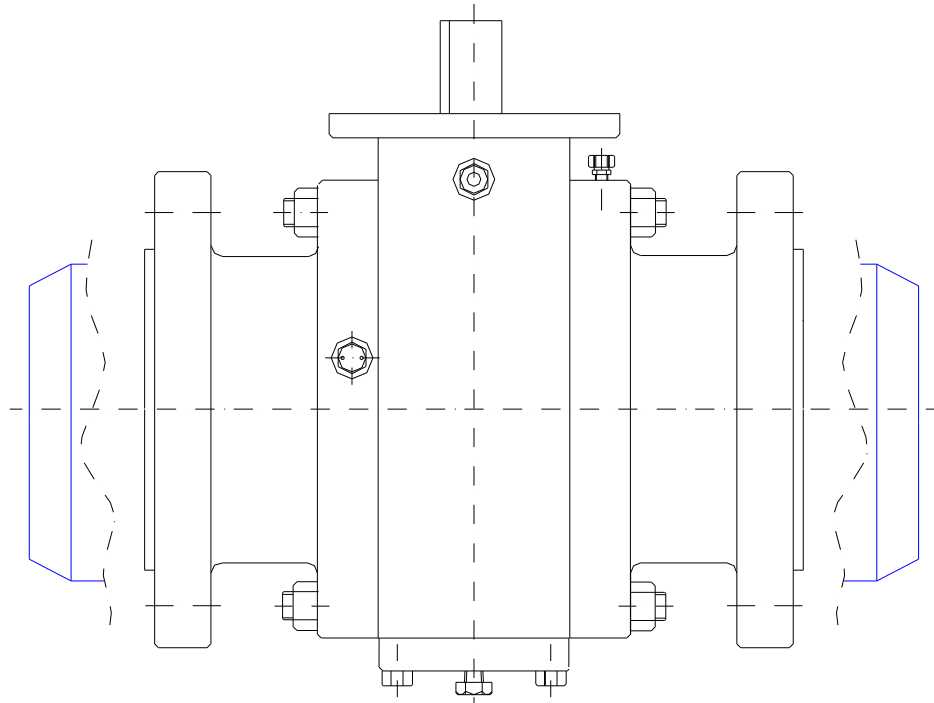

PART NAME	MATERIAL CONSTRUCTION											
	CARBON STEEL		ALLOY STEEL						STAINLESS STEEL			
BODY	A105	A350	A182						A276			
		LF2	F11	F22	F5	F9	F51	F53	304	316	304L	316L
CLOSURE / FLANGE	A105	A350	A182						A276			
		LF2	F11	F22	F5	F9	F51	F53	304	316	304L	316L
STEM	410 + ENP	A182	A182				F51	F53	A182			
		F304	F304						304	316	304L	316L
BALL	410 + ENP	A182	A182				F51	F53	A182			
		F304	F304						304	316	304L	316L
NUT	A194 2HM	A194 4	A194 7	A194 7	A194 4	A194 4	A194 8M	A194 8M	A194 8M	A194 B8M	A194 B8M	A194 8M
BOLT	A193 B7M	A320 L7	A193 B7	A193 B16	A193 B16	A193 B16	A193 B8M	A193 B8M	A193 B8M	A193 B8M	A193 B8M	A193 B8M
SEAT SEALING FACE	PTFE; RPTFE; PEEK; NYLON; HT-65											
PACKING	PTFE; GRAPHITE; O-RING (Viton)											

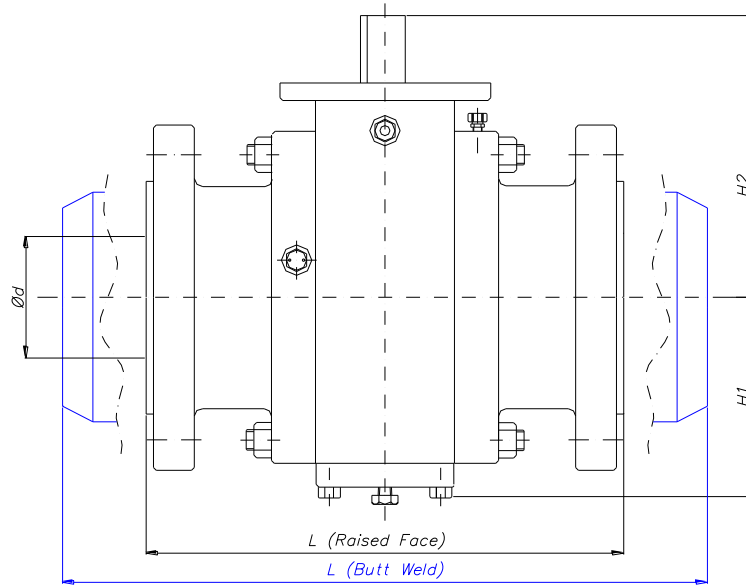



### PN 20 (Class 150)

DN	Ød	L (RF)	L (BW)	H1	H2	WEIGHT
50 (2" x 1 1/2")	38	178	216	110	160	26
50 (2")	51	178	216	120	175	30
80 (3" x 2")	51	203	283	120	175	33
80 (3")	76	203	283	150	210	60
100 (4" x 3")	76	229	305	150	210	64
100 (4")	102	229	305	165	255	103
150 (6" x 4")	102	394	457	165	255	110
150 (6")	152	394	457	190	280	188
200 (8" x 6")	152	457	521	190	280	185
200 (8")	203	457	521	225	320	250
250 (10" x 8")	203	533	559	225	320	290
250 (10")	254	533	559	265	370	435
300 (12" x 10")	254	610	635	265	370	505
300 (12")	305	610	635	280	380	610
350 (14" x 12")	305	686	762	280	380	685
350 (14")	337	686	762	310	435	825
400 (16" x 14")	337	762	838	310	435	880
400 (16")	387	762	838	350	470	1010
450 (18" x 16")	387	864	914	350	470	1100
450 (18")	438	864	914	405	510	1360
500 (20" x 18")	438	914	991	405	510	1500
500 (20")	489	914	991	460	530	1905
600 (24" x 20")	489	1067	1143	460	530	2050
600 (24")	591	1067	1143	530	635	3070
750 (30" x 24")	591	1295	1397	530	635	3300
750 (30")	737	1295	1397	660	760	5210
800 (32" x 30")	737	1371	1524	710	760	5600
800 (32")	781	1371	1524	710	790	6820
850 (34" x 32")	781	1473	1626	760	790	7200
850 (34")	813	1473	1626	760	810	7600
900 (36" x 34")	813	1524	1728	790	810	8100
900 (36")	876	1524	1728	790	890	8810

(\* ) Dimensions in mm and weight in kg.

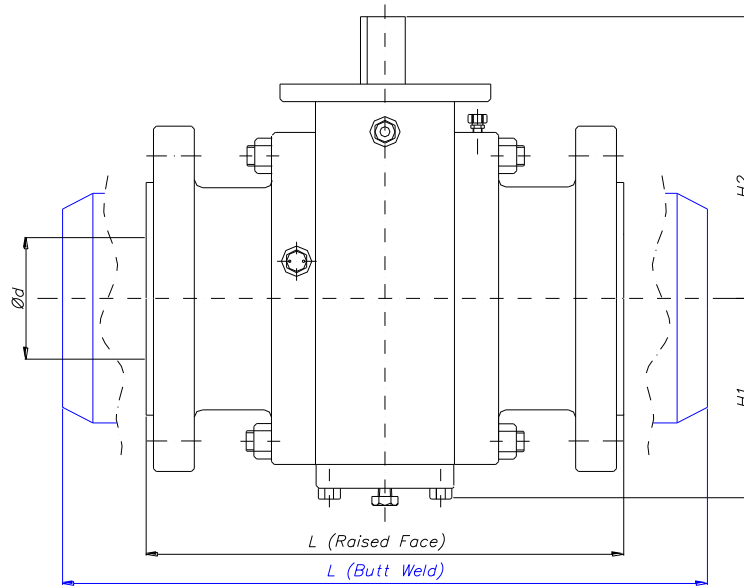

### PN 50 (Class 300)

DN	Ød	L (RF)	L (BW)	H1	H2	WEIGHT
50 (2" x 1 1/2")	38	216	216	110	160	32
50 (2")	51	216	216	120	175	33
80 (3" x 2")	51	283	283	120	175	36
80 (3")	76	283	283	150	210	63
100 (4" x 3")	76	305	305	150	210	93
100 (4")	102	305	305	165	255	110
150 (6" x 4")	102	403	457	165	255	140
150 (6")	152	403	457	190	280	226
200 (8" x 6")	152	502	521	195	290	222
200 (8")	203	502	521	230	325	305
250 (10" x 8")	203	568	559	230	325	415
250 (10")	254	568	559	290	355	554
300 (12" x 10")	254	648	35	290	355	585
300 (12")	305	648	635	305	395	740
350 (14" x 12")	305	762	762	305	395	905
350 (14")	337	762	762	330	435	1000
400 (16" x 14")	337	838	838	330	435	1160
400 (16")	387	838	838	370	470	1370
450 (18" x 16")	387	914	914	370	470	1460
450 (18")	438	914	914	430	520	1620
500 (20" x 18")	438	991	991	430	520	1810
500 (20")	489	991	991	443	570	2140
600 (24" x 20")	489	1143	1143	443	570	2420
600 (24")	591	1143	1143	545	635	3380
750 (30" x 24")	591	1397	1397	545	635	4260
750 (30")	737	1397	1397	685	790	6600
800 (32" x 30")	737	1524	1524	740	790	7200
800 (32")	781	1524	1524	740	810	7940
850 (34" x 32")	781	1625	1625	760	810	8500
850 (34")	813	1625	1625	760	810	8900
900 (36" x 34")	813	1727	1727	810	915	10100
900 (36")	876	1727	1727	810	915	11200

(\*) Dimensions in mm and weight in kg.

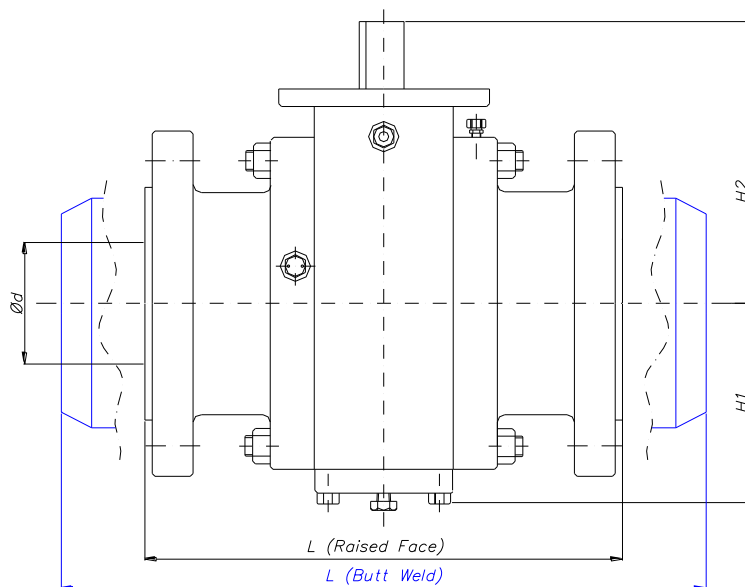

### PN 100 (Class 600)

DN	Ød	L (RF)	L (BW)	H1	H2	WEIGHT
50 (2" x 1 1/2")	38	292	292	115	160	37
50 (2")	51	292	292	125	180	40
80 (3" x 2")	51	356	356	125	180	43
80 (3")	76	356	356	160	220	75
100 (4" x 3")	76	432	432	160	220	100
100 (4")	102	432	432	170	260	139
150 (6" x 4")	102	559	559	170	260	190
150 (6")	152	559	559	190	285	275
200 (8" x 6")	203	660	660	190	280	294
200 (8")	203	660	660	254	340	445
250 (10" x 8")	203	787	787	254	340	547
250 (10")	254	787	787	305	370	720
300 (12" x 10")	254	838	838	305	370	810
300 (12")	305	838	838	330	405	910
350 (14" x 12")	305	889	889	330	405	1080
350 (14")	337	889	889	355	430	1220
400 (16" x 14")	337	991	991	355	430	1308
400 (16")	387	991	991	380	470	1528
450 (18" x 16")	387	1092	1092	380	470	1680
450 (18")	438	1092	1092	430	510	1950
500 (20" x 18")	438	1194	1194	430		2370
500 (20")	489	1194	1194	480	570	2640
600 (24" x 20")	489	1397	1397	480	570	3250
600 (24")	591	1397	1397	560	635	4580
750 (30" x 24")	591	1651	1651	560	635	5480
750 (30")	737	1651	1651	710	790	7500
800 (32" x 30")	737	1778	1778	710	790	7900
800 (32")	781	1778	1778	760	810	8400
850 (34" x 32")	781	1930	1930	760	810	8900
850 (34")	813	1930	1930	760	890	9100
900 (36" x 30")	813	2083	2083	790	890	9300
900 (36")	876	2083	2083	840	915	12500

(\*) Dimensions in mm and weight in kg.

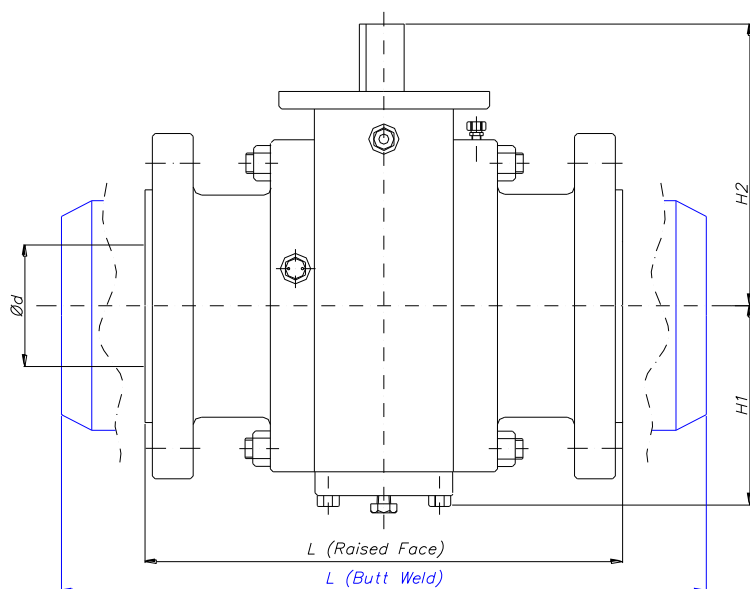

### PN 150 (Class 900)

DN	Ød	L (RF)	L (BW)	H1	H2	WEIGHT
50 (2" x 1 1/2")	38	368	368	120	170	43
50 (2")	51	368	368	130	185	53
80 (3" x 2")	51	381	381	130	185	57
80 (3")	76	381	381	165	225	92
100 (4" x 3")	76	457	457	165	225	110
100 (4")	102	457	457	175	265	166
150 (6" x 4")	102	610	610	175	265	225
150 (6")	152	610	610	190	290	380
200 (8" x 6")	152	737	737	204	305	447
200 (8")	203	737	737	240	330	569
250 (10" x 8")	203	838	838	240	330	690
250 (10")	254	838	838	305	380	910
300 (12" x 10")	254	965	965	305	380	1050
300 (12")	305	965	965	343	420	1380
350 (14" x 12")	305	1029	1029	343	420	1485
350 (14")	337	1029	1029	370	457	1650
400 (16" x 14")	337	1130	1130	370	457	1880
400 (16")	387	1130	1130	410	500	2060
450 (18" x 16")	387	1219	1219	410	500	2370
450 (18")	438	1219	1219	445	540	2860
500 (20" x 18")	438	1321	1321	445	540	3260
500 (20")	489	1321	1321	480	580	4210
600 (24" x 20")	489	1549	1549	480	580	5400
600 (24")	591	1549	1549	560	660	6850

(\*) Dimensions in mm and weight in kg.

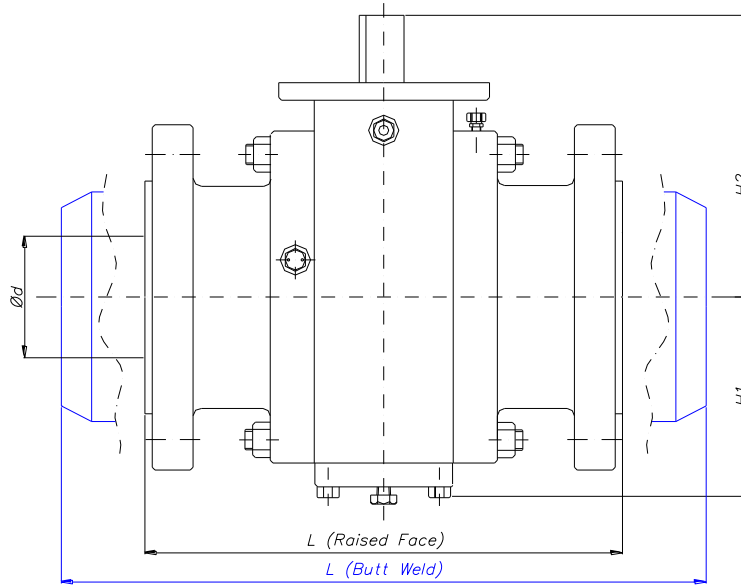

**PN 250 (Class 1500)**

DN	Ød	L (RF)	L (BW)	H1	H2	WEIGHT
50 (2")	51	368	368	140	230	53
80 (3" x 2")	51	470	470	140	230	66
80 (3")	76	470	470	160	265	98
100 (4" x 3")	76	546	546	160	265	136
100 (4")	102	546	546	190	305	204
150 (6" x 4")	102	705	705	190	305	290
150 (6")	146	705	705	230	355	520
200 (8" x 6")	146	832	832	230	355	635
200 (8")	184	832	832	305	420	854
250 (10" x 8")	194	991	991	305	420	1068
250 (10")	241	991	991	355	480	1510
300 (12" x 10")	241	1130	1130	355	480	1750
300 (12")	289	1130	1130	420	530	2450

(\*) Dimensions in mm and weight in kg.

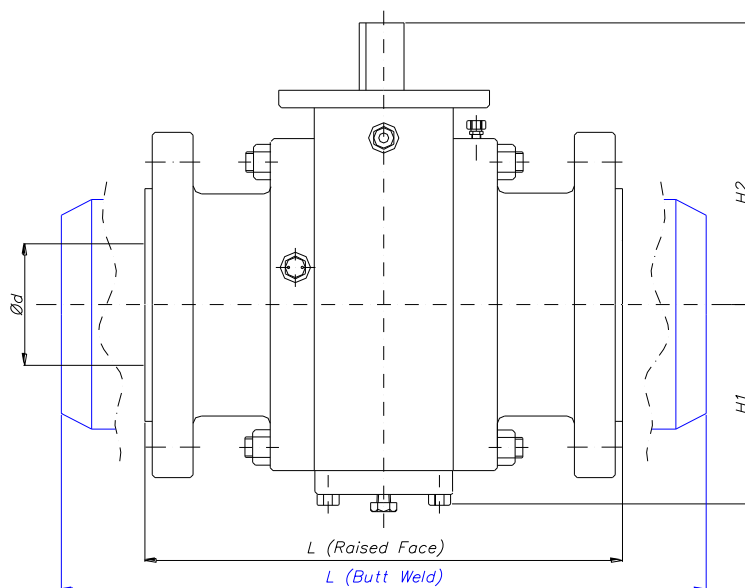

### PN 420 (Class 2500)

DN	Ød	L (RF)	L (BW)	H1	H2	WEIGHT
50 (2")	51	451	451	140	230	73
80 (3" x 2")	51	578	578	140	230	86
80 (3")	76	578	578	160	265	118
100 (4" x 3")	76	673	673	160	265	156
100 (4")	102	673	673	190	305	224
150 (6" x 4")	102	914	914	190	305	310
150 (6")	146	914	914	230	355	540
200 (8" x 6")	146	1022	1022	230	355	655
200 (8")	184	1022	1022	305	420	874
250 (10" x 8")	194	1270	1270	305	420	1088
250 (10")	241	1270	1270	355	480	1530
300 (12" x 10")	241	1422	1422	355	480	1780
300 (12")	289	1422	1422	420	530	2470

(\*) Dimensions in mm and weight in kg.



DOUBLE BLOCK AND BLEED WITH SEAT SEALING DETAIL

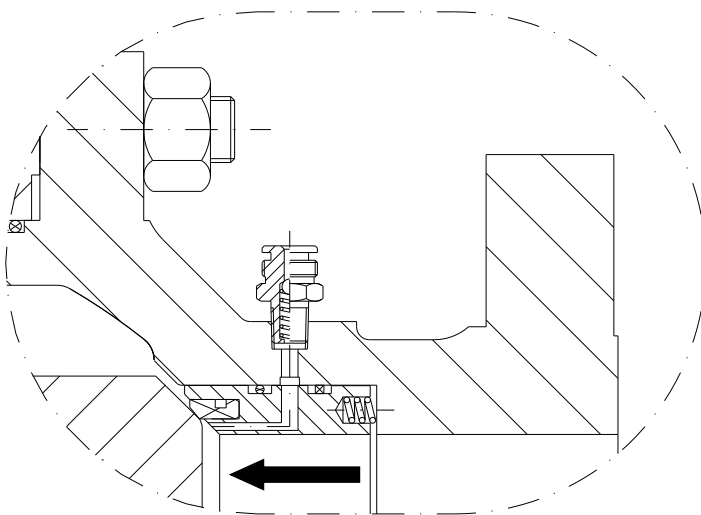

CAVITY RELIEF DETAIL

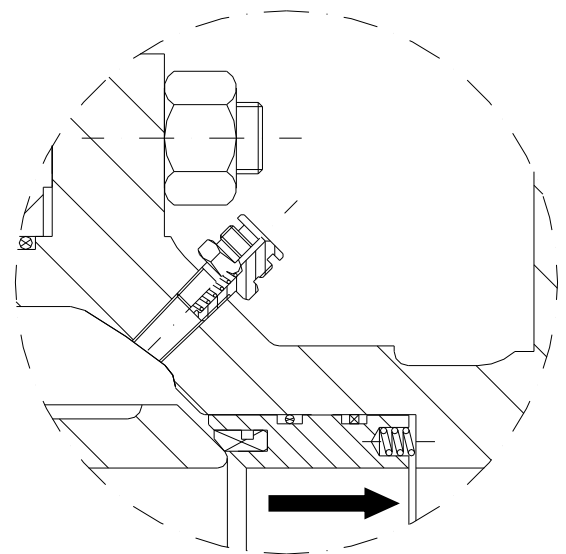

**Double Block & Bleed**

JLX VALVE ball valves sealing system allows installation in service requiring double block and bleed facility such as custom transfer metering system.

The sealing effect is a direct result of the proportional increase in differential pressure in the line acting on the floating seats.

Upstream and downstream sealing allows the discharge of the body cavity.

**Cavity Relief**

If pressure increases in body cavity due to fluid expansion, automatic relief of excess pressure to the downstream side is provided.